

**Model 610 115V Washer/High Level Disinfecter**  
**Technical Specifications**

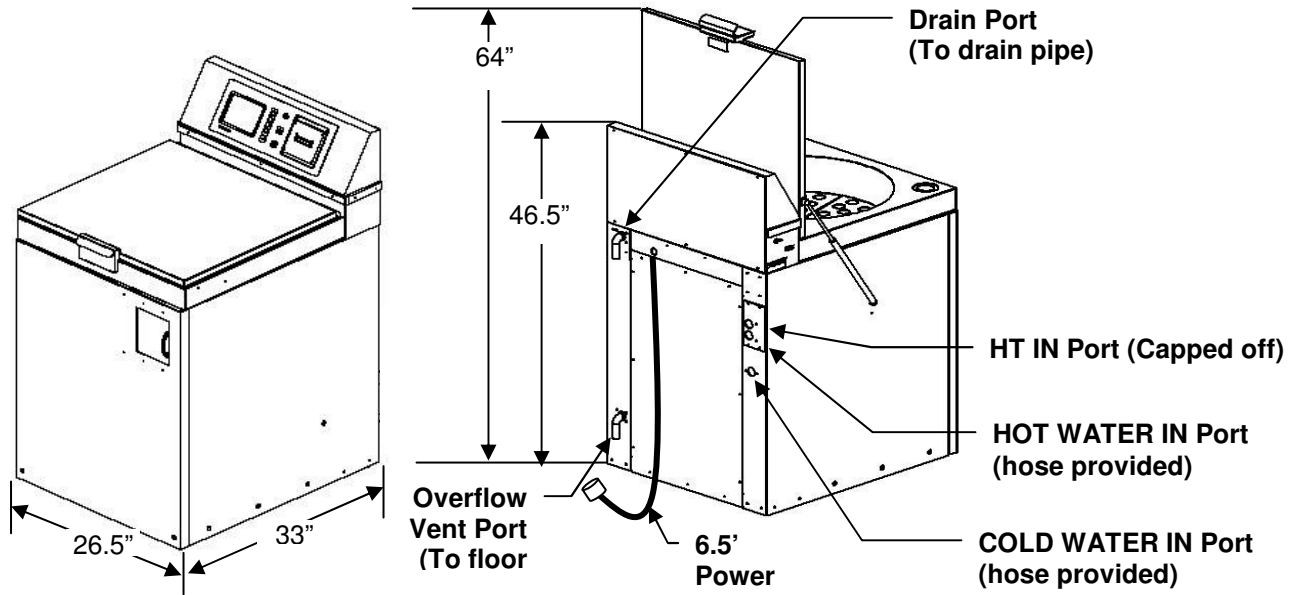

PHYSICAL SPECIFICATIONS	
WIDTH:	26 1/2" (68 cm)
DEPTH:	33" (83 cm)
HEIGHT:	46.5" (118 cm)
CLEARANCE (LID RAISED):	64" (162.6 cm)
WEIGHT (EMPTY):	243 lbs (110 kg)
(FULL):	450 lbs (204 kg)
VOLUME:	25 gal. (95 L)

ELECTRIC SPECIFICATIONS	
VOLTAGE:	115V
CYCLES:	60 Hz
CURRENT/WATTS:	20 A/2300 W
EXHAUST:	7848 BTU/HR
CIRCUIT REQ'D:	120 V, 30 A DEDICATED CIRCUIT W/ LOCKING RECEPTACLE (NEMA L5-30R)
	SEE HIGH THROUGHPUT HEATER SPECS
EQUIPPED W/:	6.5' (198.12 cm) CORD AND 30 A LOCKING PLUG (NEMA L5-30P)

PLUMBING SPECIFICATIONS
<b>WATER REQUIREMENTS:</b> 3/4" (1.90 cm) HOSE BIB FROM HOSPITAL SUPPLY (115°F-120°F (46°C-49°C) RECOMMENDED)
<b>DRAIN REQUIREMENTS:</b> 1 1/2" ID (3.8 cm) DRAIN PIPE MUST BE LOCATED AT A MINIMUM HEIGHT OF 34" (86.4 cm) FROM THE FLOOR FLOOR DRAIN RECOMMENDED

#224861 

High Level Disinfection Systems for Healthcare

Cenorin, LLC • 6324 South 199<sup>th</sup> Place • Suite 107 • Kent, WA 98032  
 Phone: 253-395-2400 • Fax: 253-395-2650 • Toll Free: 1-800-426-1042  
 FDA Registered • CSA Certified • ISO 13485:2003